

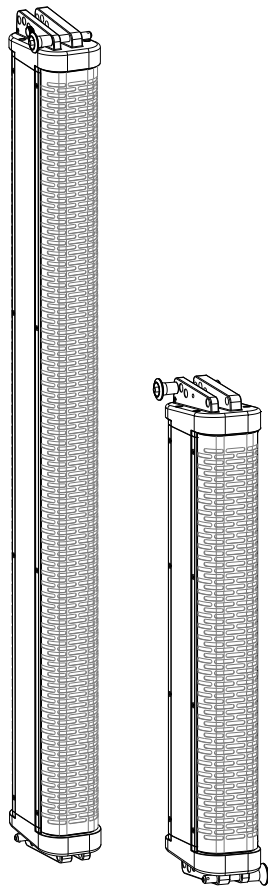

AX16CL - AX8CL

High Output Column Array Loudspeaker



USER MANUAL

revision 2023-08-08





IMPORTANT SAFETY INSTRUCTIONS

Watch for these symbols:



The lightning flash with arrowhead symbol within an equilateral triangle is intended to alert the user to the presence of uninsulated “dangerous voltage” within the product’s enclosure, that may be of sufficient magnitude to constitute a risk of electric shock to persons.



The exclamation point within an equilateral triangle is intended to alert the user to the presence of important operating and maintenance (servicing) instructions in the literature accompanying the appliance.

1. Read these instructions.
2. Keep these instructions.
3. Heed all warnings.
4. Follow all instructions.
5. Do not use this apparatus near water.
6. Clean only with dry cloth.
7. Do not block any ventilation openings. Install in accordance with the manufacturer’s instructions.
8. Do not install near any heat sources such as radiators, heat registers, stoves, or other apparatus (including amplifiers) that produce heat.
9. Do not defeat the safety purpose of the polarized or grounding-type plug. A polarized plug has two blades with one wider than the other. A grounding-type plug has two blades and a third grounding prong. The wide blade or the third prong are provided for your safety. If the provided plug does not fit into your outlet, consult an electrician for replacement of the obsolete outlet.
10. Protect the power cord from being walked on or pinched, particularly at plugs, convenience receptacles, and the point where they exit from the apparatus.
11. Only use attachments/accessories specified by the manufacturer.
12. Use only with the cart, stand, tripod, bracket, or table specified by the manufacturer, or sold with the apparatus. When a cart is used, use caution when moving the cart/apparatus combination to avoid injury from tip-over.
13. Unplug this apparatus during lightning storms or when unused for long periods of time.
14. Refer all servicing to qualified service personnel. Servicing is required when the apparatus has been damaged in any way, such as power supply cord or plug is damaged, liquid has been spilled or objects have fallen into the apparatus, the apparatus has been exposed to rain or moisture, does not operate normally, or has been dropped.
15. Warning: to reduce the risk of fire or electric shock, do not expose this apparatus to rain or moisture.
16. Do not expose this equipment to dripping or splashing and ensure that no objects filled with liquids, such as vases, are placed on the equipment.
17. To completely disconnect this apparatus from the ac mains, disconnect the power supply cord plug from the ac receptacle.
18. The mains plug of the power supply cord shall remain readily operable.
19. This apparatus contains potentially lethal voltages. To prevent electric shock or hazard, do not remove the chassis, input module or ac input covers. No user serviceable parts inside. Refer servicing to qualified service personnel.
20. The loudspeakers covered by this manual are not intended for high moisture outdoor environments. Moisture can damage the speaker cone and surround and cause corrosion of electrical contacts and metal parts. Avoid exposing the speakers to direct moisture.
21. Keep loudspeakers out of extended or intense direct sunlight. The driver suspension will prematurely dry out and finished surfaces may be degraded by long-term exposure to intense ultra-violet (UV) light.
22. The loudspeakers can generate considerable energy. When placed on a slippery surface such as polished wood or linoleum, the speaker may move due to its acoustical energy output.
23. Precautions should be taken to assure that the speaker does not fall off a stage or table on which it is placed.
24. The loudspeakers are easily capable of generating sound pressure levels (SPL) sufficient to cause permanent hearing damage to performers, production crew and audience members. Caution should be taken to avoid prolonged exposure to SPL in excess of 90 dB.



This marking shown on the product or its literature, indicates that it should not be disposed with other household wastes at the end of its working life. To prevent possible harm to the environment or human health from uncontrolled waste disposal, please separate this from other types of wastes and recycle it responsibly to promote the sustainable reuse of material resources. Household users should contact either the retailer where they purchased this product, or their local government office, for details of where and how they can take this item for environmentally safe recycling. Business users should contact their supplier and check the terms and conditions of the purchase contract. This product should not be mixed with other commercial wastes for disposal.



DECLARATION OF CONFORMITY

CE The product is in compliance with:
RoHS Directive 2011/65/EU and 2015/863/EU, WEEE Directive 2012/19/EU.

**UK
CA** The product is in compliance with:
S.I. 2012/3032 The Restriction of the Use of Certain Hazardous Substances in Electrical and Electronic Equipment Regulations 2012

LIMITED WARRANTY

Proel warrants all materials, workmanship and proper operation of this product for a period of two years from the original date of purchase. If any defects are found in the materials or workmanship or if the product fails to function properly during the applicable warranty period, the owner should inform about these defects the dealer or the distributor, providing receipt or invoice of date of purchase and defect detailed description. This warranty does not extend to damage resulting from improper installation, misuse, neglect or abuse. Proel S.p.A. will verify damage on returned units, and when the unit has been properly used and warranty is still valid, then the unit will be replaced or repaired. Proel S.p.A. is not responsible for any "direct damage" or "indirect damage" caused by product defectiveness.

- This unit package has been submitted to ISTA 1A integrity tests. We suggest you control the unit conditions immediately after unpacking it.
- If any damage is found, immediately advise the dealer. Keep all unit packaging parts to allow inspection.
- Proel is not responsible for any damage that occurs during shipment.
- Products are sold "delivered ex warehouse" and shipment is at charge and risk of the buyer.
- Possible damages to unit should be immediately notified to forwarder. Each complaint for package tampered with should be done within eight days from product receipt.

CONDITIONS OF USE

Proel do not accept any liability for damage caused to third parties due to improper installation, use of non-original spare parts, lack of maintenance, tampering or improper use of this product, including disregard of acceptable and applicable safety standards. Proel strongly recommends that this loudspeaker cabinet be suspended taking into consideration all current National, Federal, State and Local regulations. The product must be installed by qualified personal. Please contact the manufacturer for further information.



INDEX

INTRODUCTION	4
TECHNICAL SPECIFICATION	4
AX16CL MECHANICAL DRAWING	5
AX8CL MECHANICAL DRAWING	6
OPTIONAL ACCESSORIES	6
SPARE PARTS	6
REAR PANEL	7
PREDICTION SOFTWARE: EASE FOCUS 3	8
SYSTEM PROCESSING BASIC INSTRUCTION	8
BASIC INSTALLATION INSTRUCTIONS	8
PIN LOCKING AND SPLAY ANGLES SET UP	9
STACKED INSTALLATION USING SW212A SUBWOOFER AS BASE	10
STACKED INSTALLATION USING KPTSTANDAX16CL FLOOR STAND	11
STACKED INSTALLATION USING KPTFAX16CL FLOOR	

STAND	13
STACKED INSTALLATION WITH KPTPOLEAX16CL POLE ADAPTER	15
FLOOR AND FRONT FILL INSTALLATION USING KPTFAXCL FOAM STAND	16
FLOOR/FRONT FILL, SIDE WALL, CEILING/UNDER BALCONY INSTALLATION USING KPTWAX8CL C-BRACKET	16
WALL INSTALLATION USING KPTWAX16CLL BRACKETS	17
WALL INSTALLATION USING KPTWAX16CL AND KPTWAX16CLL BRACKETS	18
WALL INSTALLATION USING KPTWAX16CL BRACKETS	19
SUSPENDED INSTALLATION USING KPTAX16CL FLYBAR	20

INTRODUCTION

The AX16CL Line Array is a passive system equipped with sixteen 2.5" neodymium transducers with waterproof cones, designed for portable and permanently installed applications where high power and clarity are needed. The aluminum frame box structure ensures lightweight and strength, while the shape features a back-loaded transmission line design with clean mid-bass reproduction and natural cardioid behaviour. The wide horizontal dispersion make the system flexible and adaptable to many different applications.

The AX16CL line array module has been designed to be combined with the SW212A, a compact and lightweight double 12" Bass-Reflex subwoofer, equipped with a 2800W Class D amplifier with Power Factor Correction and PROEL's proprietary 40bit floating point CORE2 DSP. Up to four AX16CL modules can be driven by one amplifier channel of the SW212A subwoofer. The built-in CORE2 DSP, which can be also remotely controlled using PRONET AX software, provides 4 presets for different combinations: 2, 4 or 1 columns plus 1 user preset.

The standard system, composed of four AX16CL line array modules and two SW212A subwoofers, features 5600W of total power and a line-array dispersion pattern, making it the perfect solution for high-performance portable sound reinforcement applications. Thanks to the elegant mechanical design the AX16CL can be easily transported, while the integrated suspension system makes its deployment very fast and simple. Each unit comes with two aluminum brackets and four pins that allows multiple array elements to be easily combined either together or with the matching SW212A subwoofer, or also in combination with the complete range of mounting hardware available, including flybar and several brackets and stands.

The AX8CL is a column half-size of the AX16CL, so the two models can be combined together to form a more flexible column array that can be pointed more precisely to the audience.

TECHNICAL SPECIFICATION

SYSTEM		INPUT CONNECTIONS	
System's Acoustic Principle	Line Array Element Short Transmission Line Back Loading	Connector Type	Neutrik® Speakon® NL4 x 2 (1+/1- signal IN & LINK ; 2+/2- thru)
POWER HANDLING		ENCLOSURE & CONSTRUCTION	
Frequency Response (±3dB)	200 Hz - 16 KHz (Processed)	Continuous AES Pink Noise Power	320 W (AX16CL) / 160W (AX8CL)
Nominal Impedance	32 Ω (AX16CL) / 64 Ω (AX8CL)	Program Power	640 W (AX16CL) / 320W (AX8CL)
Minimum Impedance	23.7 Ω (AX16CL) / 49 Ω (AX8CL)	Width	90 mm (3.54")
Horizontal Coverage Angle	80° (-6 dB)	Height (AX16CL)	1190 mm (46.85")
Sensitivity (4V) SPL @ 1m*	103 dB (AX16CL) / 94 dB (AX8CL)	Height (AX8CL)	654 mm (25.76")
Maximum Peak SPL @ 1m	128 dB (AX16CL) / 122 dB (AX8CL)	Depth	154 mm (6.06")
<i>*measured @4 m and scaled @1 m</i>		Enclosure Material	Aluminum
TRANSDUCERS		Paint	High resistance, water based paint, black or white finish
Type	16 (AX16CL) / 8 (AX8CL) 2.5" (66mm) Neodymium magnet, full range, 0.8" (20mm) VC	Flying system	Aluminum Fast Link structure with dedicated pins
Cone	Waterproof Cone	Net Weight (AX16CL)	11.5 kg / 25.4 lbs
Voice Coil Type	Ventilated voice coil	Net Weight (AX8CL)	6 kg / 12.2 lbs

AX16CL MECHANICAL DRAWING

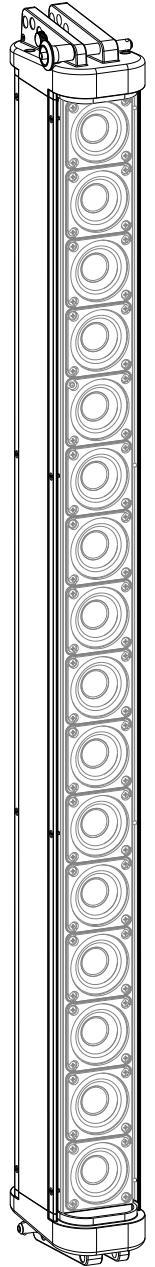
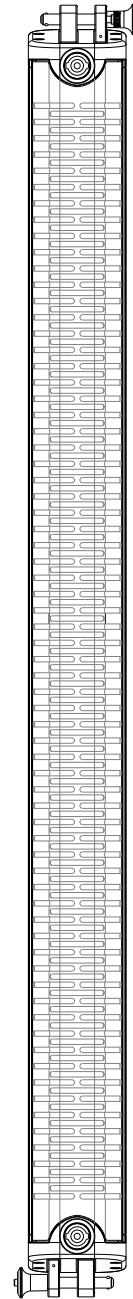
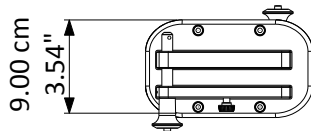
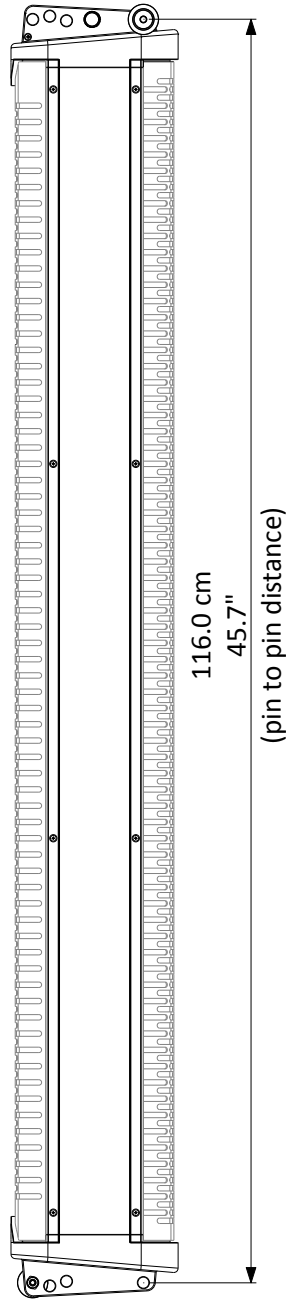
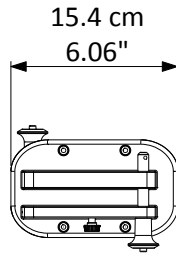
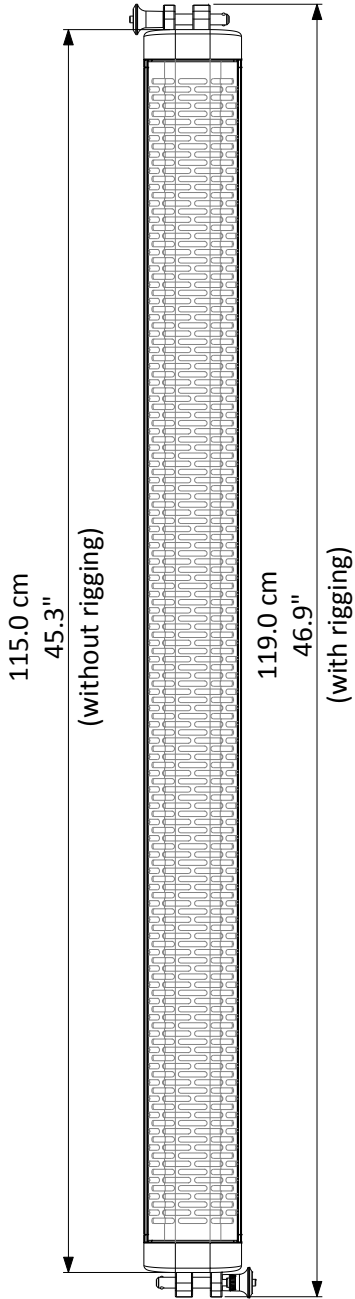



AX8CL MECHANICAL DRAWING

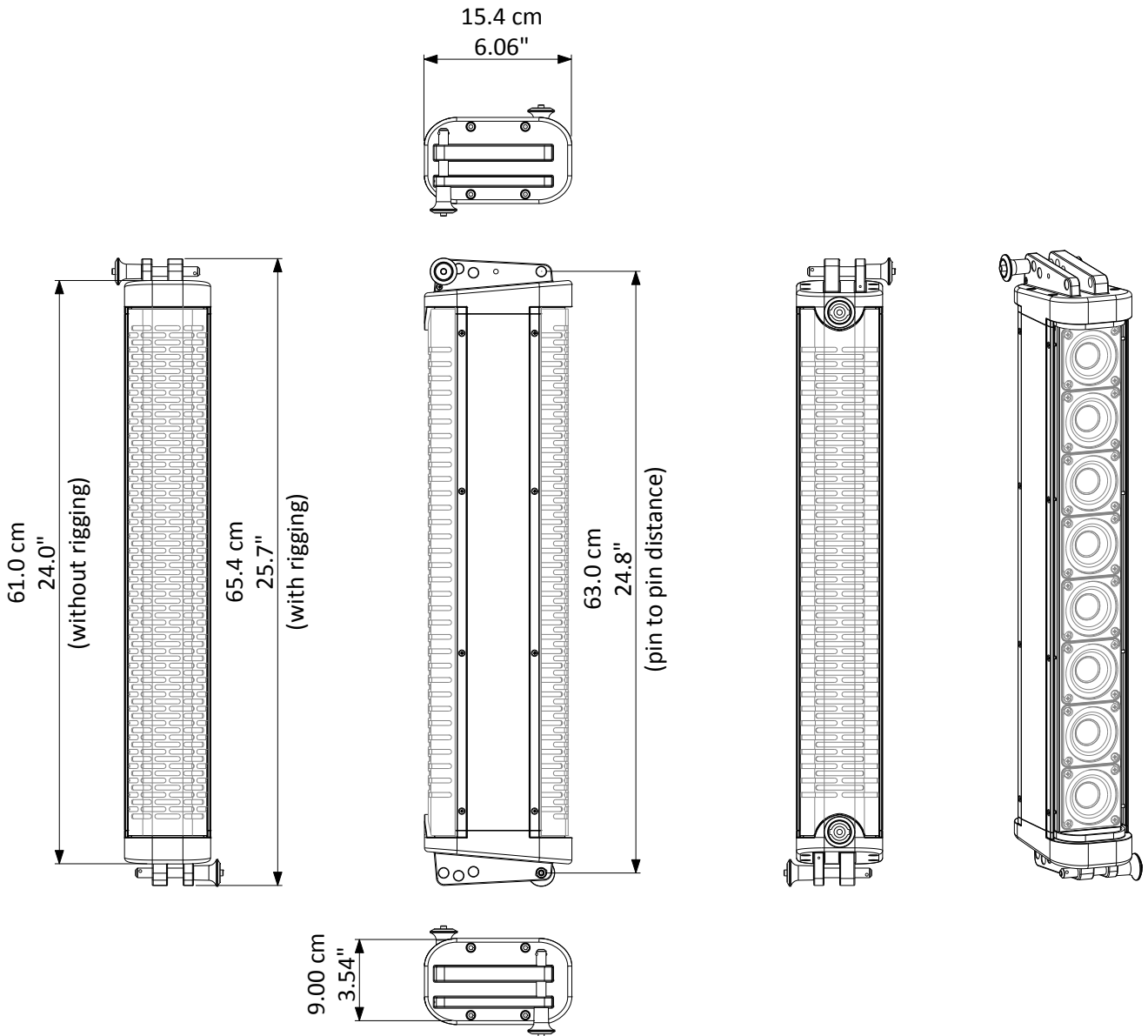

OPTIONAL ACCESSORIES

COVERAX16CL	Cover / carrying bag for single AX16CL	KPTFAXCL	Foam adapters for stage monitor or frontfill application
COVERAX8CL	Cover / carrying bag for single AX8CL	KPTFAX16CL	Floor stand for up to 2 units AX16CL
ESO2500LU025	25 cm SPEAKON linking cable 4x4mm	KPTSTANDAX16CL	Floor stand for up to 2 units AX16CL
NL4FX	Neutrik Speakon® PLUG	KPTPOLEAX16CL	Pole adapter for 1 unit AX16CL
KPTWAX8CL	Wall/Floor bracket for AX8CL (C-shape)	DHSS10M20	∅35mm 1-1.7m Pole with Handle and M20 screw
KPTWAX16CL	Wall bracket for AX16CL (Strong)	KP210S	∅35mm 0.7-1.2m Pole with M20 screw
KPTWAX16CLL	Wall bracket for AX16CL (Light)	KPTAX16CL	Flybar for suspending AX16CL and AX8CL
		PLG716	Straight Shackle 16 mm for Fly bar

see <http://www.axiomproaudio.com> for detailed description and other available accessories.

SPARE PARTS

94SPI10555	Locking Pin	NL4MP	Neutrik Speakon® panel socket
		98ALT200009	2.5" speaker - 0.8" VC - 8 ohm



REAR PANEL

INPUT & LINK - Both connectors at the top and the bottom of the AX16CL/AX8CL can operate as input or link, to connect an appropriated processed amplifier or to link the column to a second one.

The AX16CL/AX8CL does not include an internal passive crossover for filtering the signal, but only an internal protection that excludes the internal speaker to protect them from excessive input power. The protection should not trip with a typical music program, but only with a massive and constant power signal, like a feedback. The connections are the following:

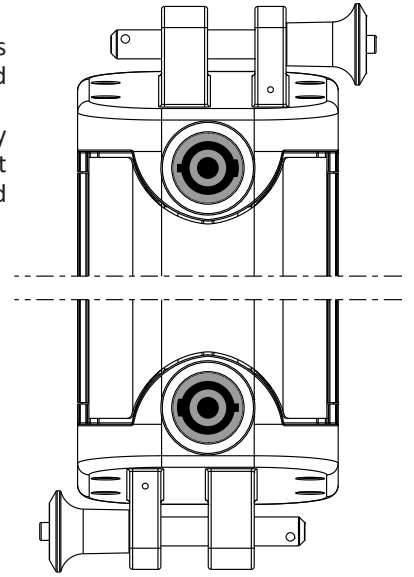

INPUT - LINK	
NL4 pin number	internal connection
1+	+ speakers (pass thru link speakon)
1-	- speakers (pass thru link speakon)
2+	+ no connection (pass thru link speakon)
2-	- no connection (pass thru link speakon)

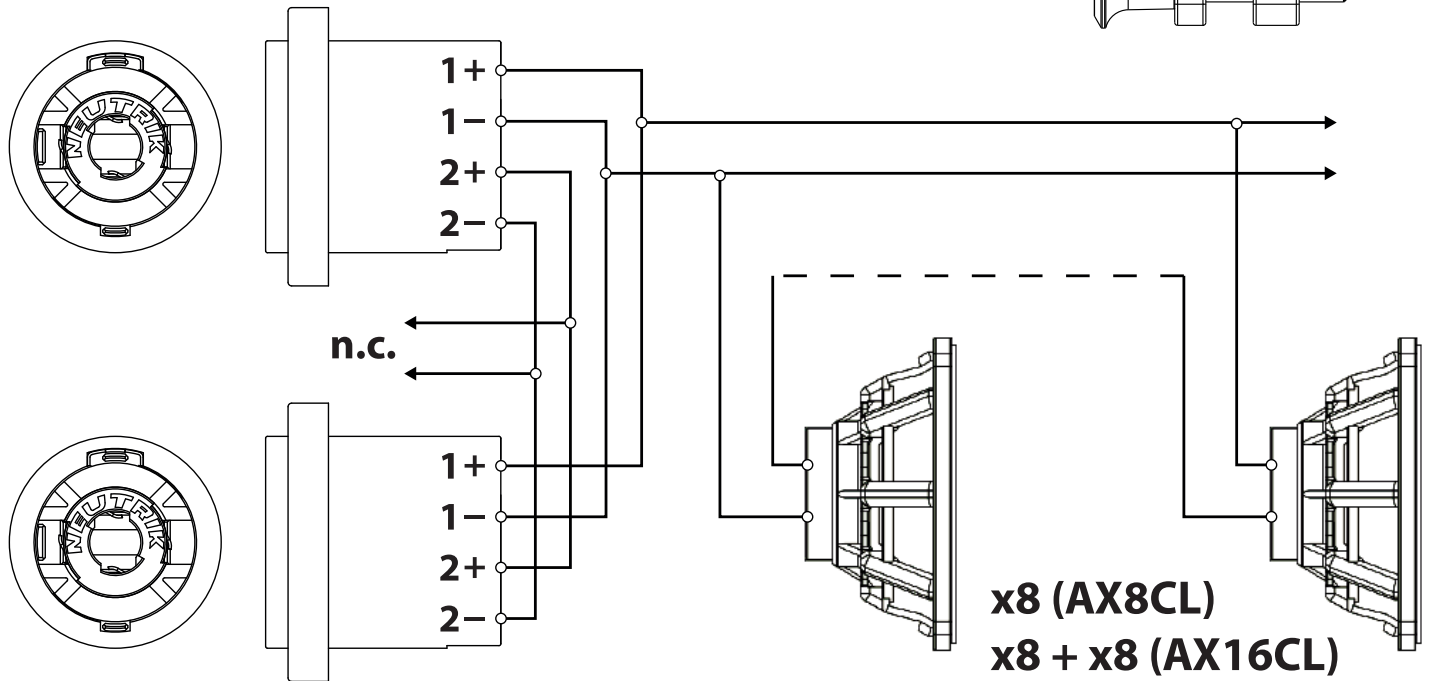

WARNING:

The maximum quantity of AX16CL that can be linked together depends by the load capacity of the appropriate processed amplifier. When powered from the SW212A subwoofer or from the QC2.4 suggested amplifier, a maximum of four AX16CL can be connected to each power output.



PREDICTION SOFTWARE: EASE FOCUS 3

To aim correctly a complete system of AX16CL and/or AX8CL (SW212A always stays on the floor) we suggests to use always the suitable aiming software:

EASE Focus 3 Aiming Software is a 3D Acoustic Modelling Software that serves for the configuration and modelling of Line Arrays and conventional speakers close to reality. It only considers the direct field, created by the complex addition of the sound contributions of the individual loudspeakers or array components.

The design of EASE Focus is targeted at the end user. It allows the easy and quick prediction of the array performance in a given venue. The scientific base of EASE Focus stems from EASE, the professional electro- and room acoustic simulation software developed by AFMG Technologies GmbH. It is based on the EASE GLL loudspeaker data file required for its use. The GLL file contains the data that defines the Line Array with regard to its possible configurations as well as to its geometrical and acoustical properties.

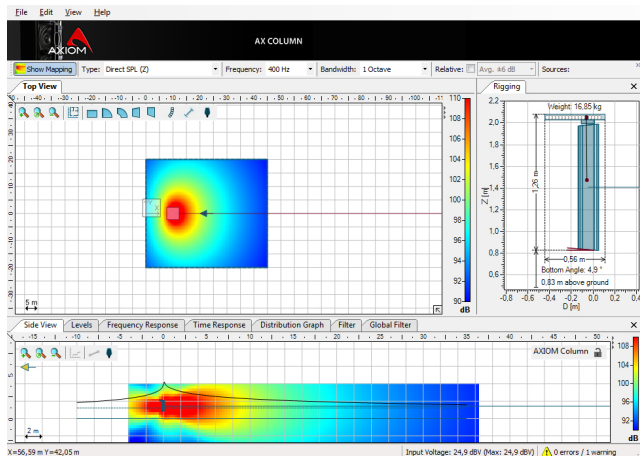

Download the EASE Focus 3 app from the AXIOM website at <https://www.axiomproaudio.com/> clicking on downloads section of the product.

Use the menu option **Edit / Import System Definition File** to import the GLL file, the detailed instructions to use the program are located in the menu option **Help / User's Guide**.

Note: Some windows system can require the .NET Framework 4 that can be download from website at <https://focus.afmg.eu/>.

SYSTEM PROCESSING BASIC INSTRUCTION

AX16CL/AX8CL need an external processor to take care of the filtering, the time alignment and the speaker protection. When powered from the SW212A amplifier output, the sub-woofer's CORE2 DSP takes care of all the processing and three different presets are available:

SW212A PRESET	Elements of Column Array		
	AX16CL	AX8CL	AX16CL + AX8CL
2 x AX16CL	2 to 3	3 to 4	1 + 1 to 2
4 x AX16CL	3 to 4	6 to 8	1 + 4 to 8 or 2 + 2 to 4 or 3 + 1 to 2
1 x AX16CL	1	1 to 2	1 + 1

As can be seen from the table some combinations of array elements can be used with different presets. For example if you have 3 AX16CL you can use both the 2 x AX16CL preset and the 4 x AX16CL preset, depending on the balance between subwoofer and columns you want to obtain: by choosing 2x there the balance will be shifted towards the high frequencies, while by choosing 4x the balance will be shifted towards the low frequencies.

Using the PRONET AX software, additional EQ, LEVEL and DELAY adjustments can be added to the basic presets and new presets can be saved in the SW212A user memories.

When using the QC2.4 or QC 4.4 amplifiers to power the AX16CL/AX8CL, the correct presets must be loaded into the amplifier's DSP memory according to the number of columns connected.

BASIC INSTALLATION INSTRUCTIONS



WARNING! CAREFULLY READ THE FOLLOWING INSTRUCTIONS AND CONDITION OF USE:

- This loudspeaker is designed exclusively for Professional audio applications. The product must be installed by qualified personal only.
- Proel strongly recommends that this loudspeaker cabinet be suspended taking into consideration all current National, Federal, State and Local regulations. Please contact the manufacturer for further information.
- Proel do not accept any liability for damage caused to third parties due to improper installation, lack of maintenance, tampering or improper use of this product, including disregard of acceptable and applicable safety standards.
- During assembly pay attention to the possible risk of crushing. Wear suitable protective clothing. Observe all instructions given on the rigging components and the loudspeaker cabinets. When chain hoists are in operation ensure that there is nobody directly underneath or in the vicinity of the load. Do not under any circumstances climb on the array.





PIN LOCKING AND SPLAY ANGLES SET UP

The figure below shows how to insert correctly the locking pin and how to set up the splay angle between loudspeakers.

LOCKING PIN INSERTION

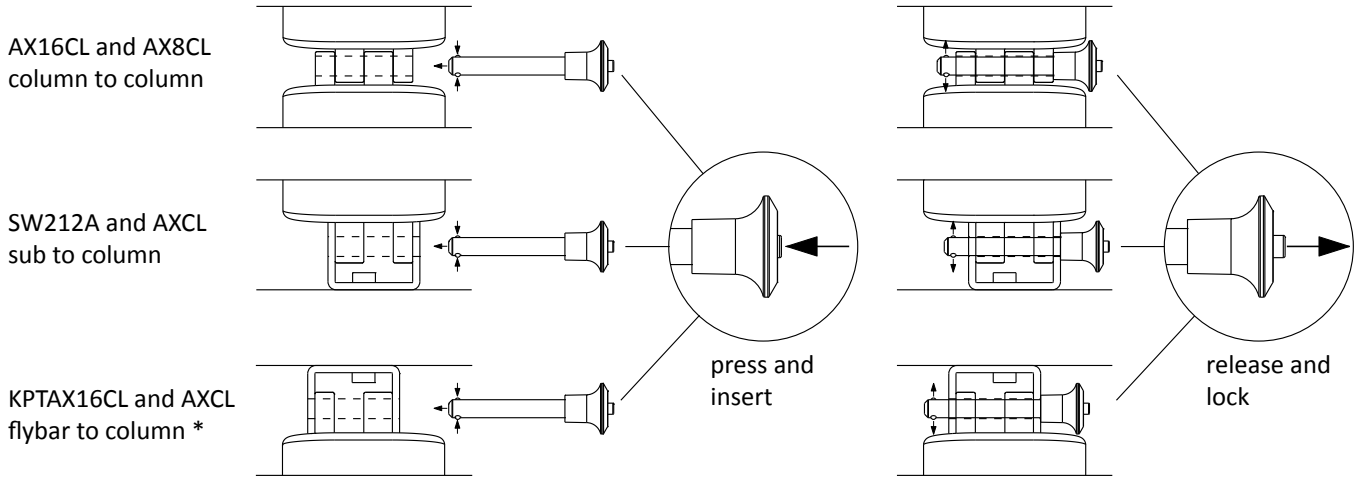

* all accessories have similar insertion and locking

SPLAY ANGLE SET UP

SW212A/KPT ACCESSORIES

Use these holes for the SW212A or the accessories splay angle:

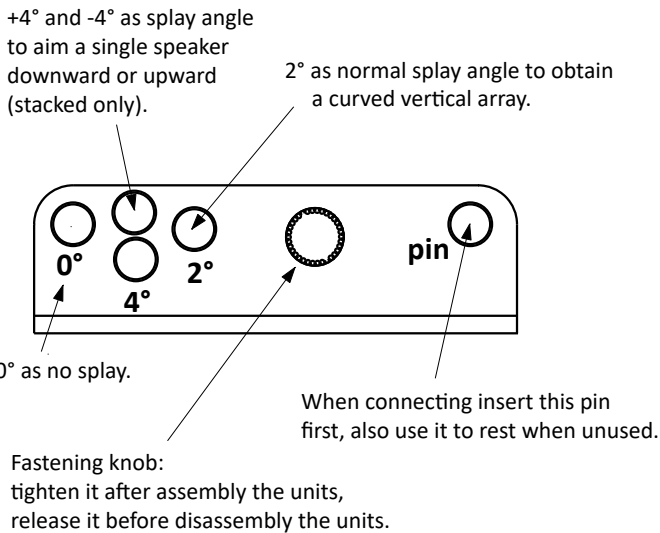

AX16CL/AX8CL

Use these holes for the column speaker splay angle:

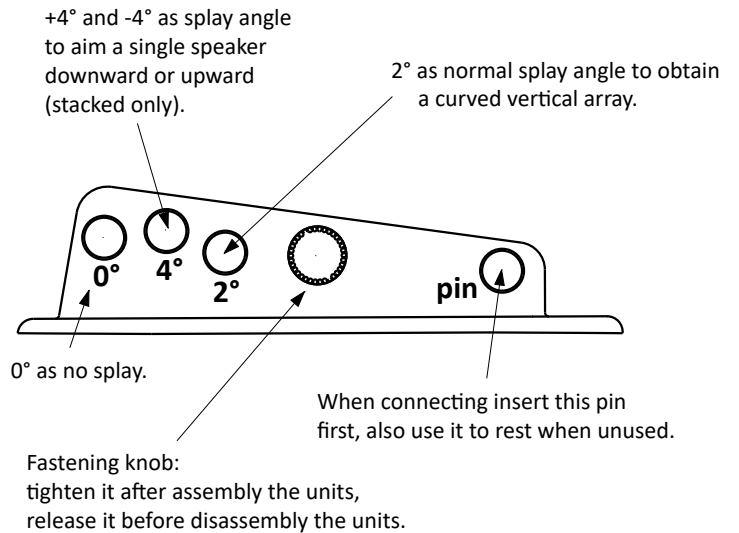

Each of the following examples has some symbols at the connection points: these symbols indicate if a splay angle is allowed or is prohibited for safety or acoustical reason:

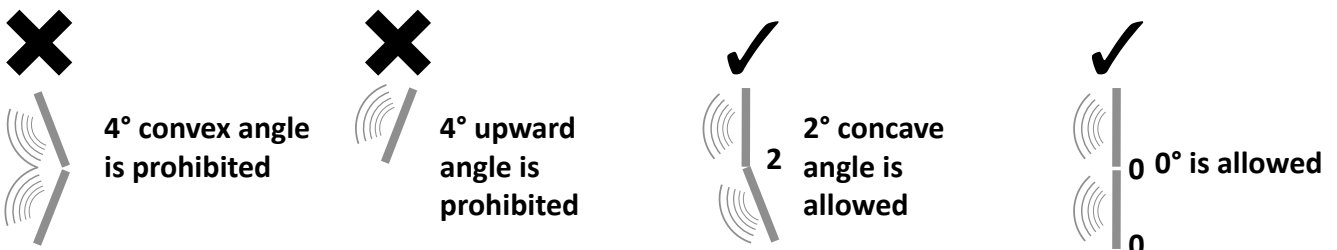



STACKED INSTALLATION USING SW212A SUBWOOFER AS BASE



WARNINGS:

- The ground where the SW212A is placed needs to be stable and compact.
- Adjust the feet so to put the SW212A perfectly horizontal. Use a spirit level to obtain the best results.
- Always secure ground stacked setups against movement and possible tipping over.
- A maximum of 2x AX16CL or 4x AX8CL or 1x AX16CL + 2x AX8CL speakers are allowed to be installed over a SW212A serving as ground support.
- The optimal splay angles can be simulated using the EASE Focus 3 software.

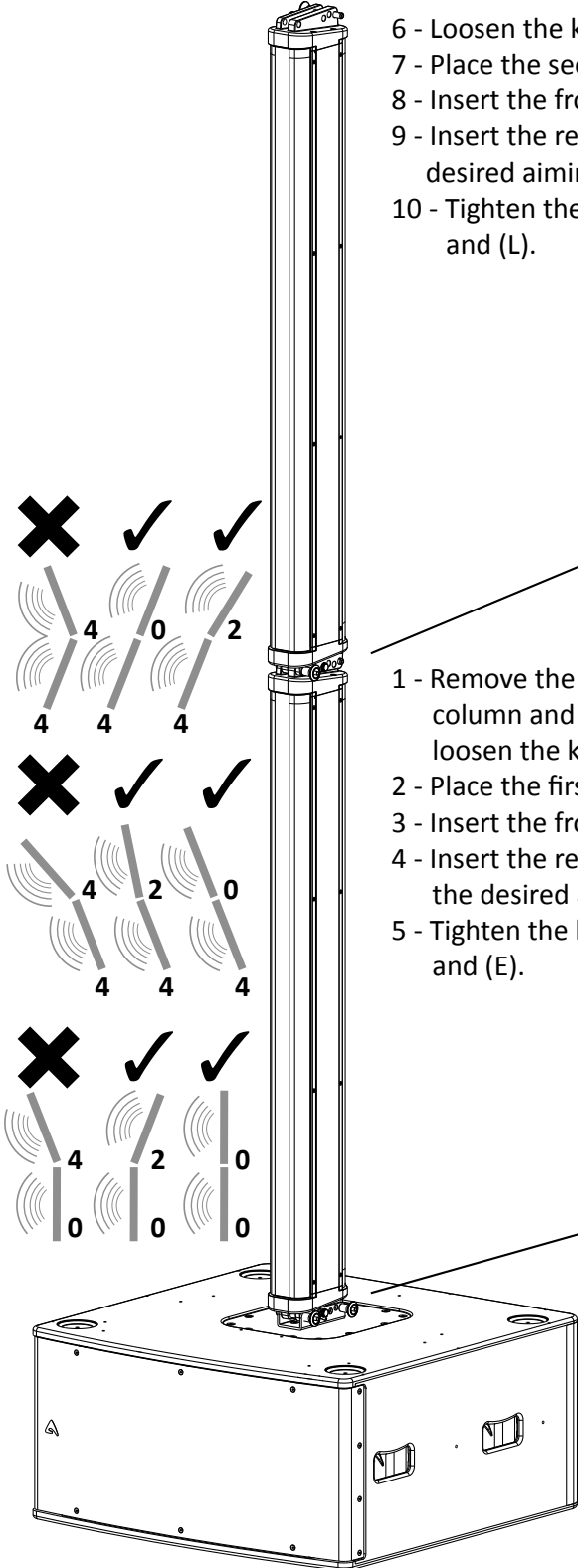

- 6 - Loosen the knobs (H) and (L).
- 7 - Place the second column (I).
- 8 - Insert the front pin (F).
- 9 - Insert the rear pin (G) in the desired aiming position.
- 10 - Tighten the knobs (H) and (L).

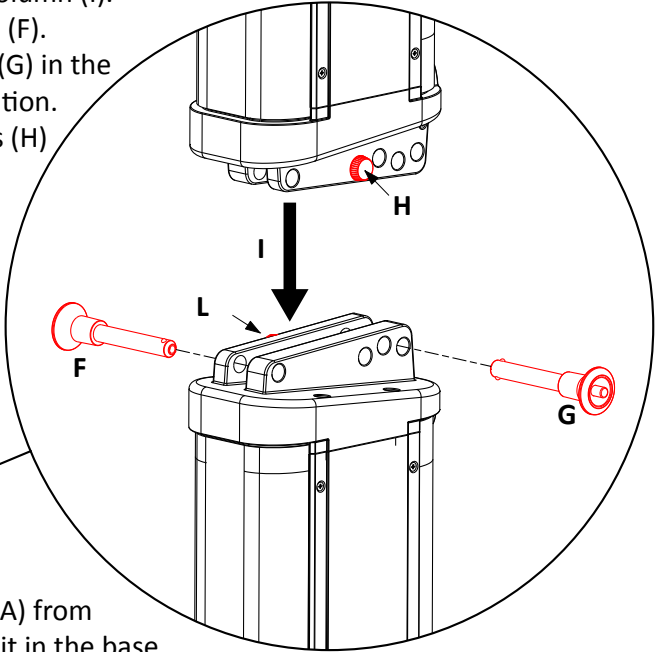

- 1 - Remove the knob (A) from column and screw it in the base, loosen the knob (E).
- 2 - Place the first column (B).
- 3 - Insert the front pin (C).
- 4 - Insert the rear pin (D) in the desired aiming position.
- 5 - Tighten the knobs (A) and (E).

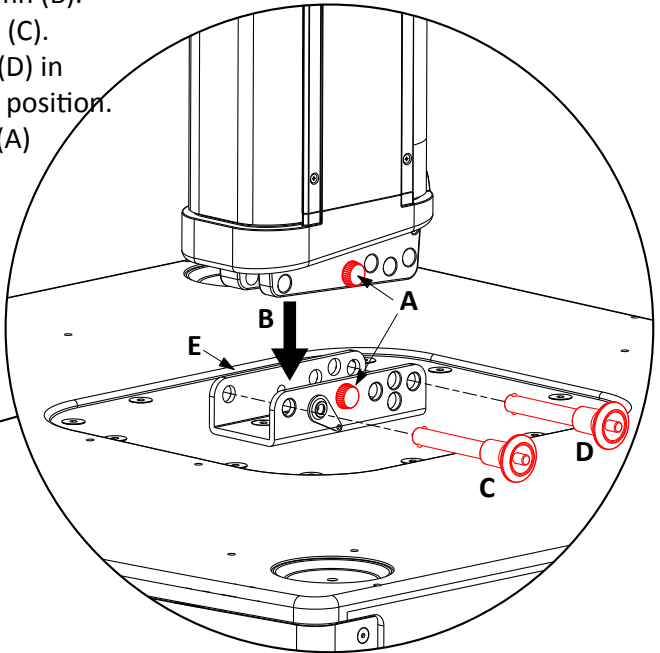



STACKED INSTALLATION USING KPTSTANDAX16CL FLOOR STAND



WARNINGS:

- The ground where the KPTSTANDAX16CL floor stand is placed needs to be stable and compact.
- Adjust the feet so to put the KPTSTANDAX16CL perfectly horizontal. Use a spirit level to obtain the best result.
- Always secure ground stacked setups against movement and possible tipping over.
- A maximum of 2 x AX16CL or 4 x AX8CL or 1x AX16CL + 2x AX8CL speakers are allowed to be installed over a KPTSTANDAX16CL serving as ground support.
- When 2 column units are stacked both must be setup with 0° aiming.

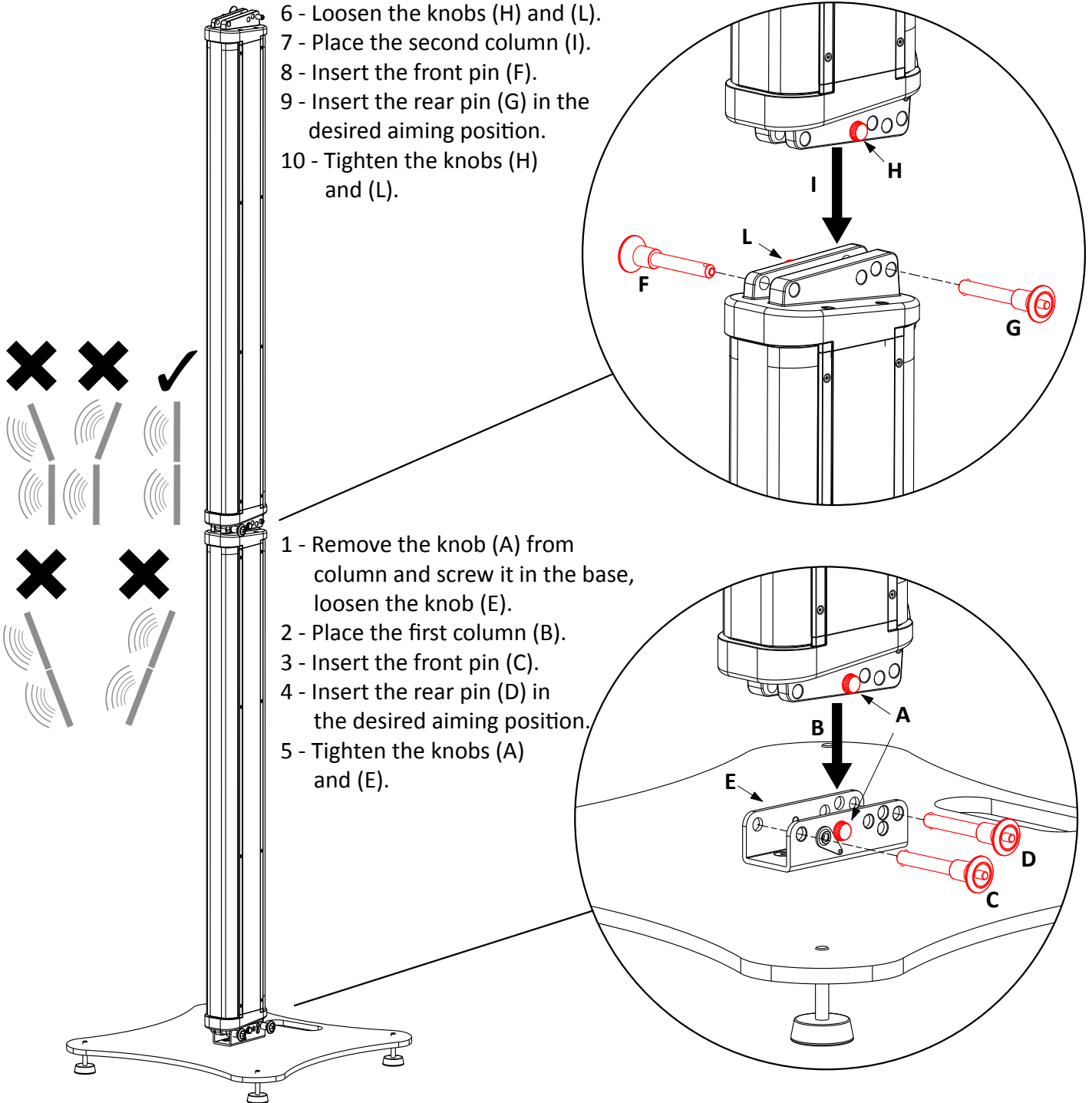

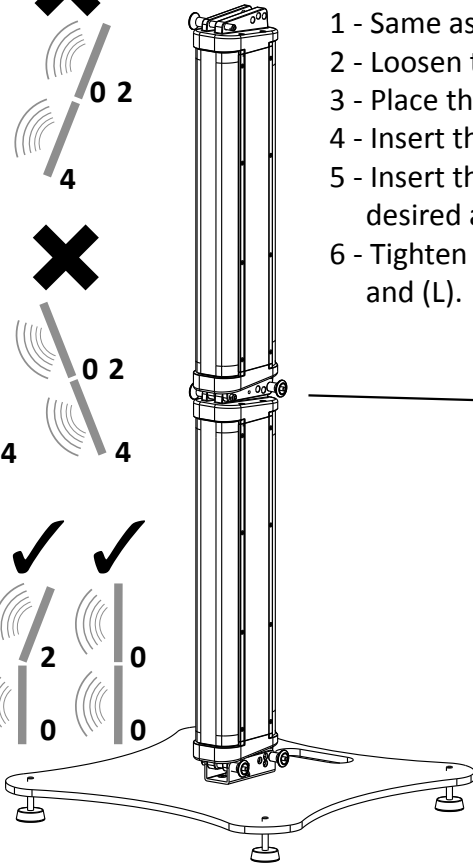
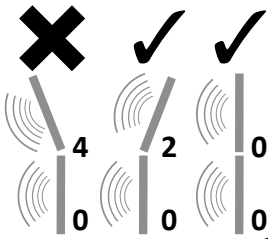
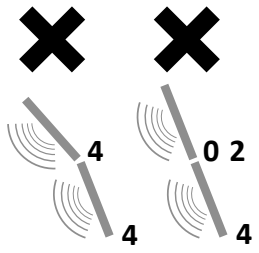
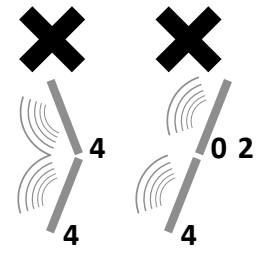

- 1 - Same as below.
- 2 - Loosen the knobs (H) and (L).
- 3 - Place the second column (I).
- 4 - Insert the front pin (F).
- 5 - Insert the rear pin (G) in the desired aiming position.
- 6 - Tighten the knobs (H) and (L).

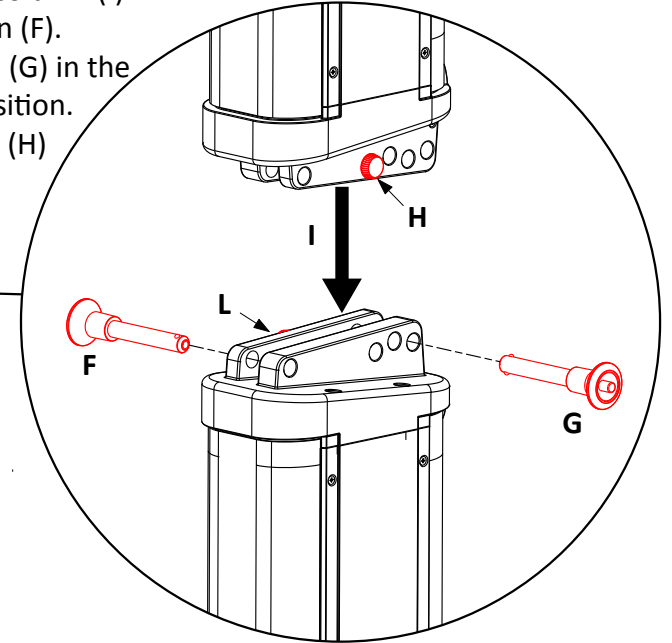

- 1 - Remove the knob (A) from column and screw it in the base, loosen the knob (E).
- 2 - Place the first column (B).
- 3 - Insert the front pin (C).
- 4 - Insert the rear pin (D) in the desired aiming position.
- 5 - Tighten the knobs (A) and (E).

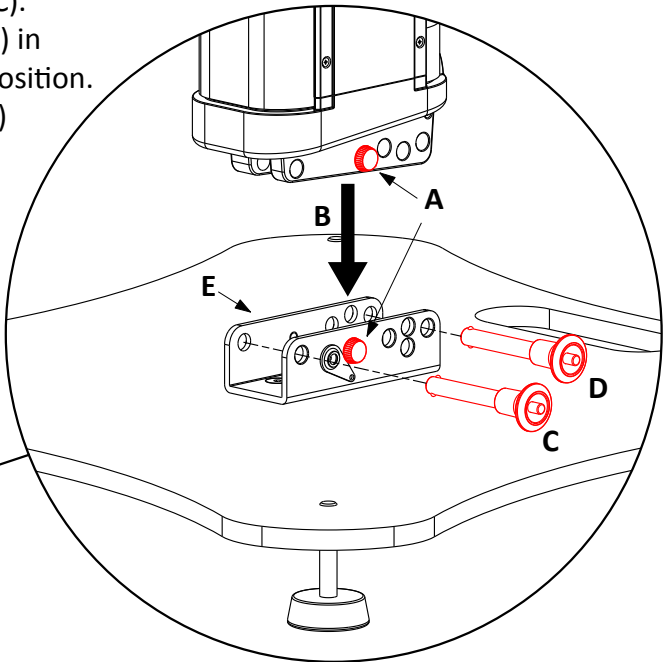
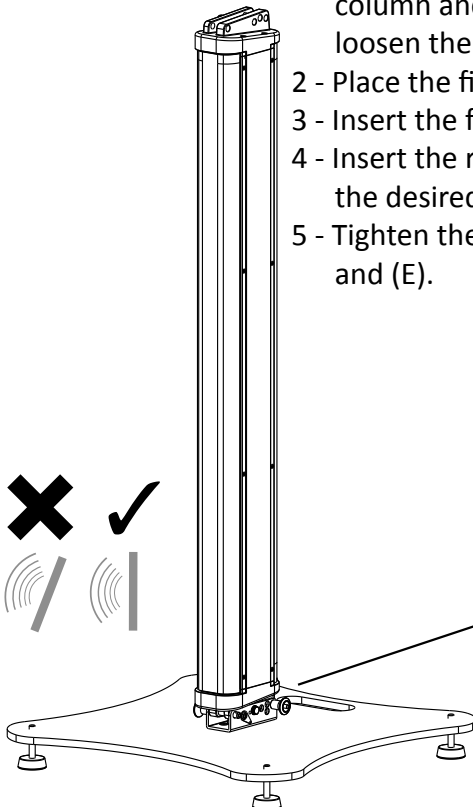
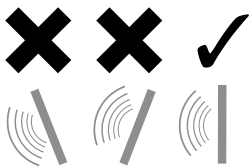



STACKED INSTALLATION USING KPTFAX16CL FLOOR STAND



WARNINGS:

- The ground where the KPTFAX16CL floor stand is placed needs to be stable and compact.
- Adjust the feet so to put the KPTFAX16CL perfectly horizontal. Use a spirit level to obtain the best result.
- Always secure ground stacked setups against movement and possible tipping over.
- A maximum of 2 x AX16CL or 4 x AX8CL or 1x AX16CL + 2x AX8CL speakers are allowed to be installed over a KPTFAX16CL serving as ground support.
- When 2 column units are stacked both must be setup with 0° aiming.

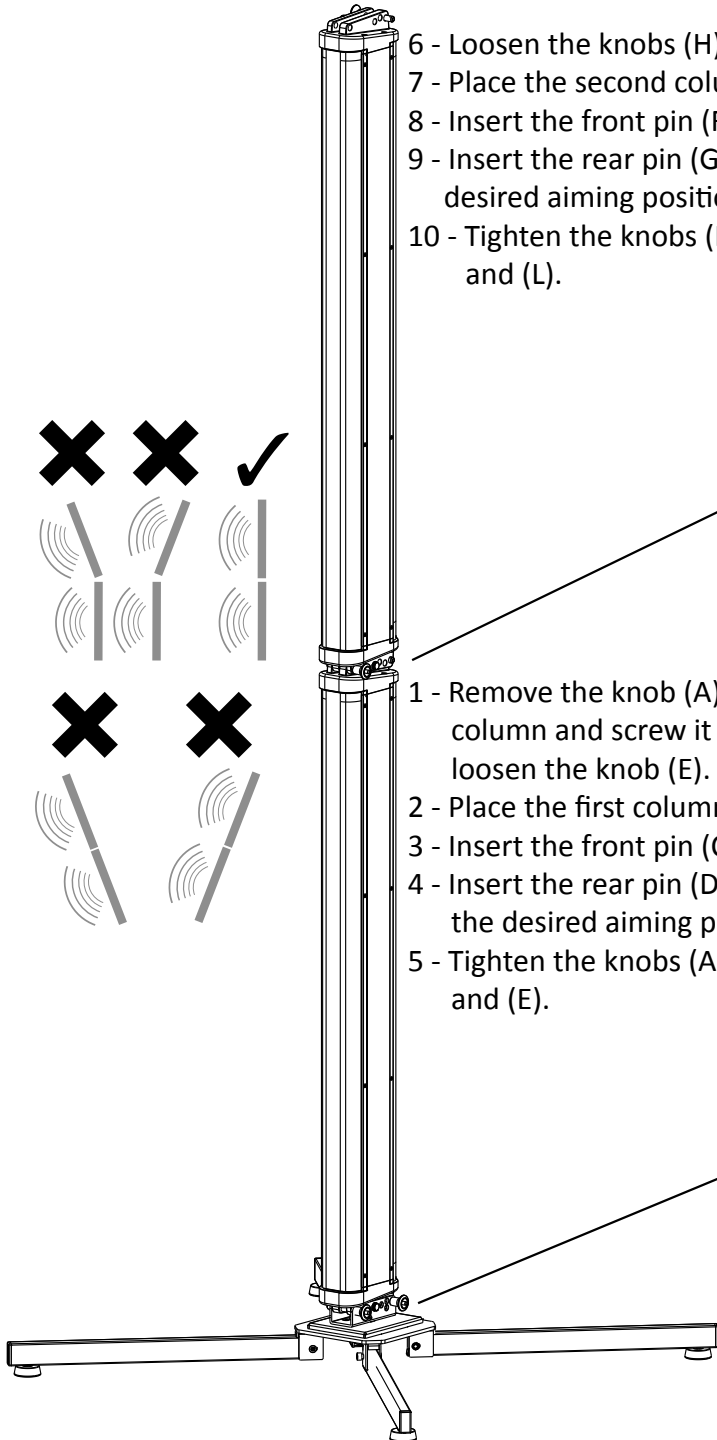

- 6 - Loosen the knobs (H) and (L).
- 7 - Place the second column (I).
- 8 - Insert the front pin (F).
- 9 - Insert the rear pin (G) in the desired aiming position.
- 10 - Tighten the knobs (H) and (L).

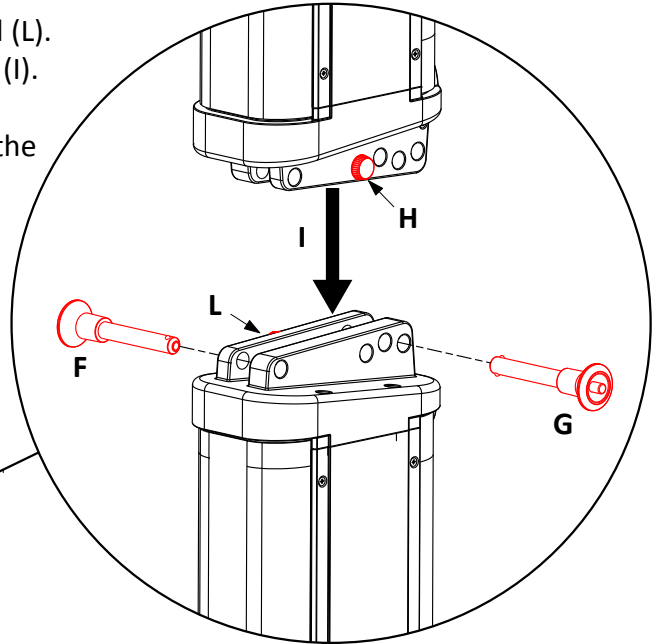

- 1 - Remove the knob (A) from column and screw it in the base, loosen the knob (E).
- 2 - Place the first column (B).
- 3 - Insert the front pin (C).
- 4 - Insert the rear pin (D) in the desired aiming position.
- 5 - Tighten the knobs (A) and (E).

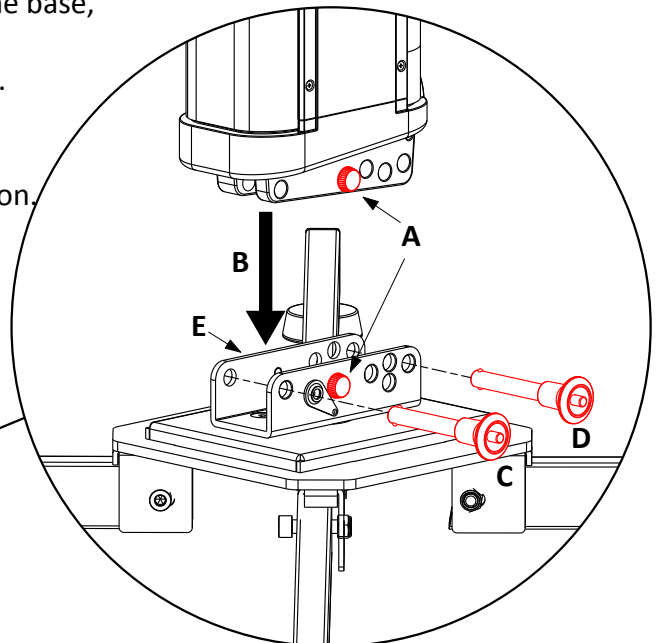

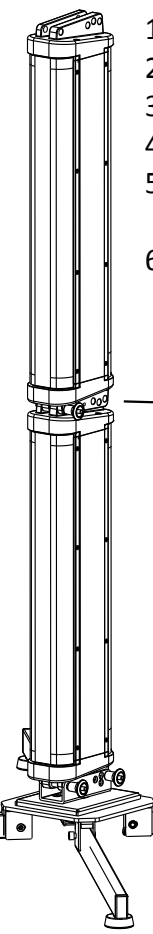
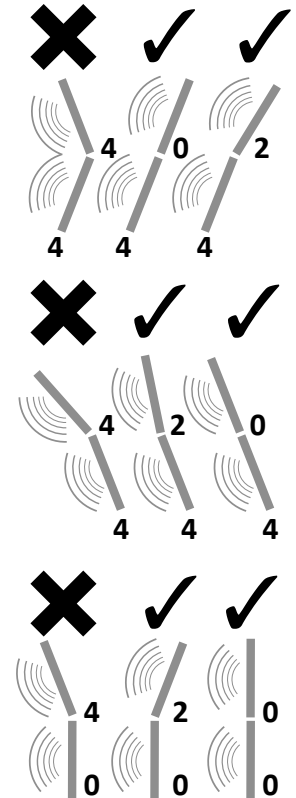

- 1 - Same as below.
- 2 - Loosen the knobs (H) and (L).
- 3 - Place the second column (I).
- 4 - Insert the front pin (F).
- 5 - Insert the rear pin (G) in the desired aiming position.
- 6 - Tighten the knobs (H) and (L).

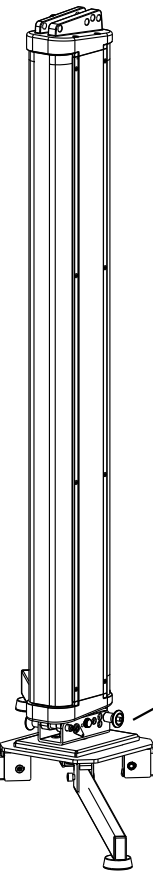
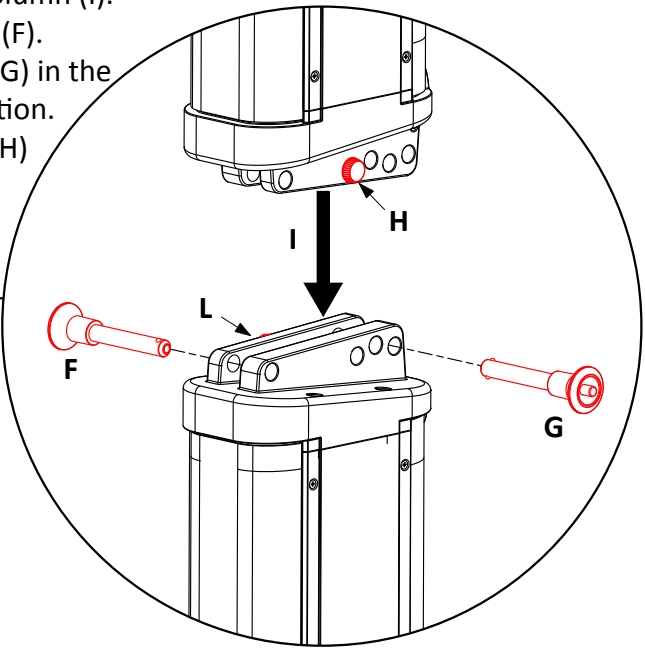

- 1 - Remove the knob (A) from column and screw it in the base, loosen the knob (E).
- 2 - Place the first column (B).
- 3 - Insert the front pin (C).
- 4 - Insert the rear pin (D) in the desired aiming position.
- 5 - Tighten the knobs (A) and (E).

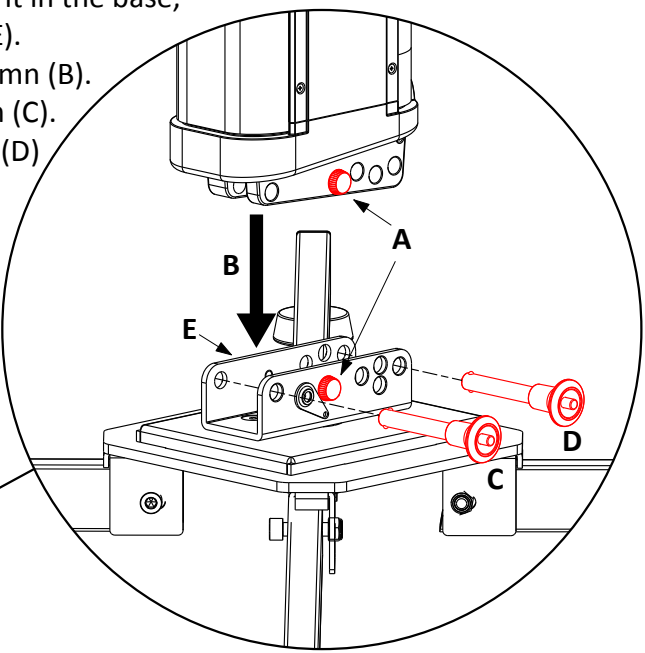



STACKED INSTALLATION WITH KPTPOLEAX16CL POLE ADAPTER

The KPTPOLEAX16CL is used in combination with the KP210S or DHSS10M20 pole on the KPTFAX16CL floor stand as base.



WARNINGS:

- The ground where the KPTFAX16CL floor stand is placed needs to be stable and compact.
- Adjust the feet so to put the KPTFAX16CL perfectly horizontal. Use a spirit level to obtain the best result.
- Always secure ground stacked setups against movement and possible tipping over.
- A maximum of 1 x AX16CL or 2 x AX8CL speakers are allowed to be installed over a KPTFAX16CL with pole serving as ground support.
- The column must be setup with 0° aiming.

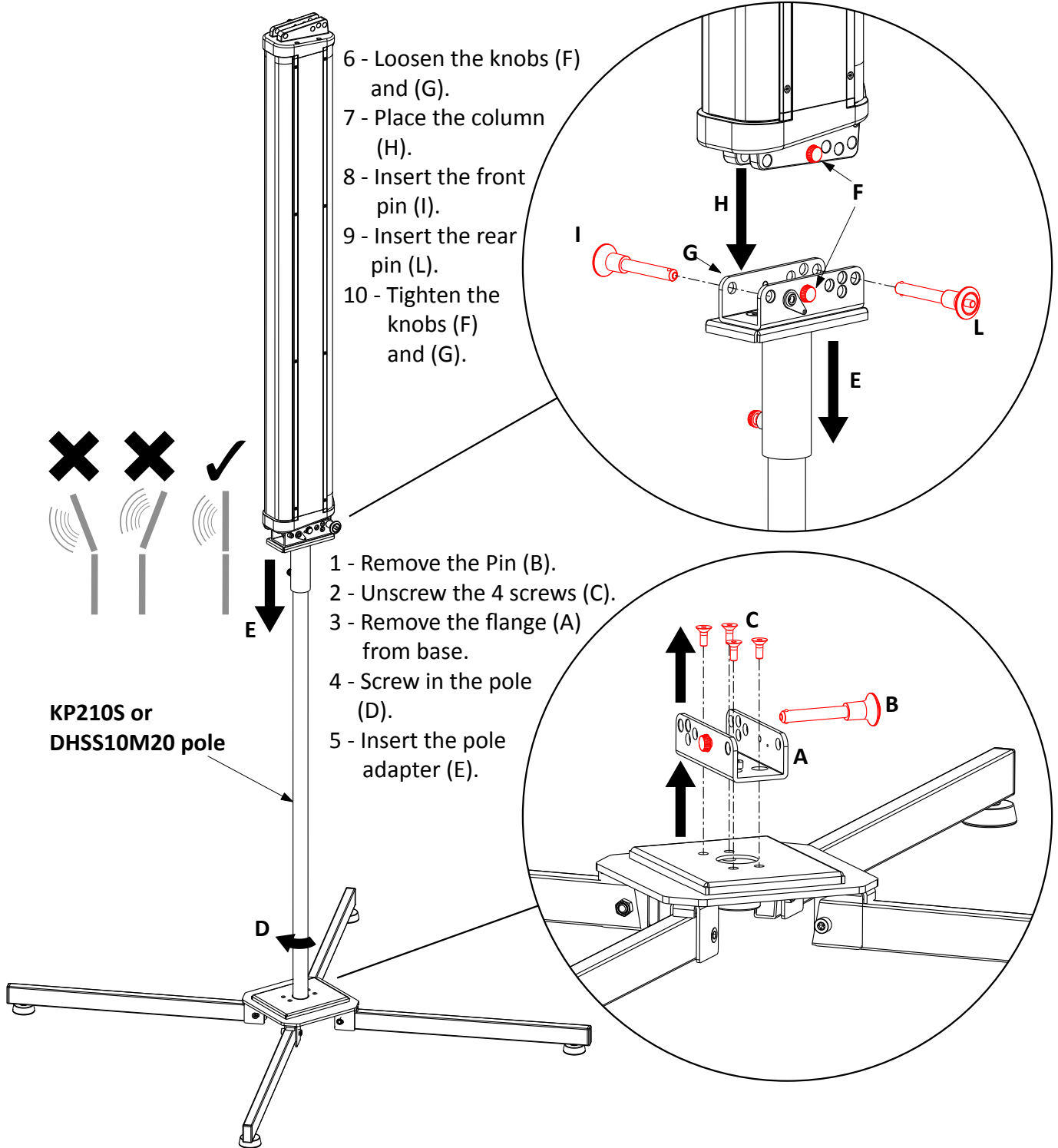



FLOOR AND FRONT FILL INSTALLATION USING KPTFAXCL FOAM STAND



WARNINGS:

- KPTFAX8CL can be used in front-fill or monitor applications on stage.
- The ground where the KPTFAXCL foam stand is placed needs to be stable and compact.
- When using this support for frontfill application, place it on a stable surface. If it is placed on a front line subwoofer, it must be secured to it using a strap, because the subwoofer vibrations could cause it to fall to ground.

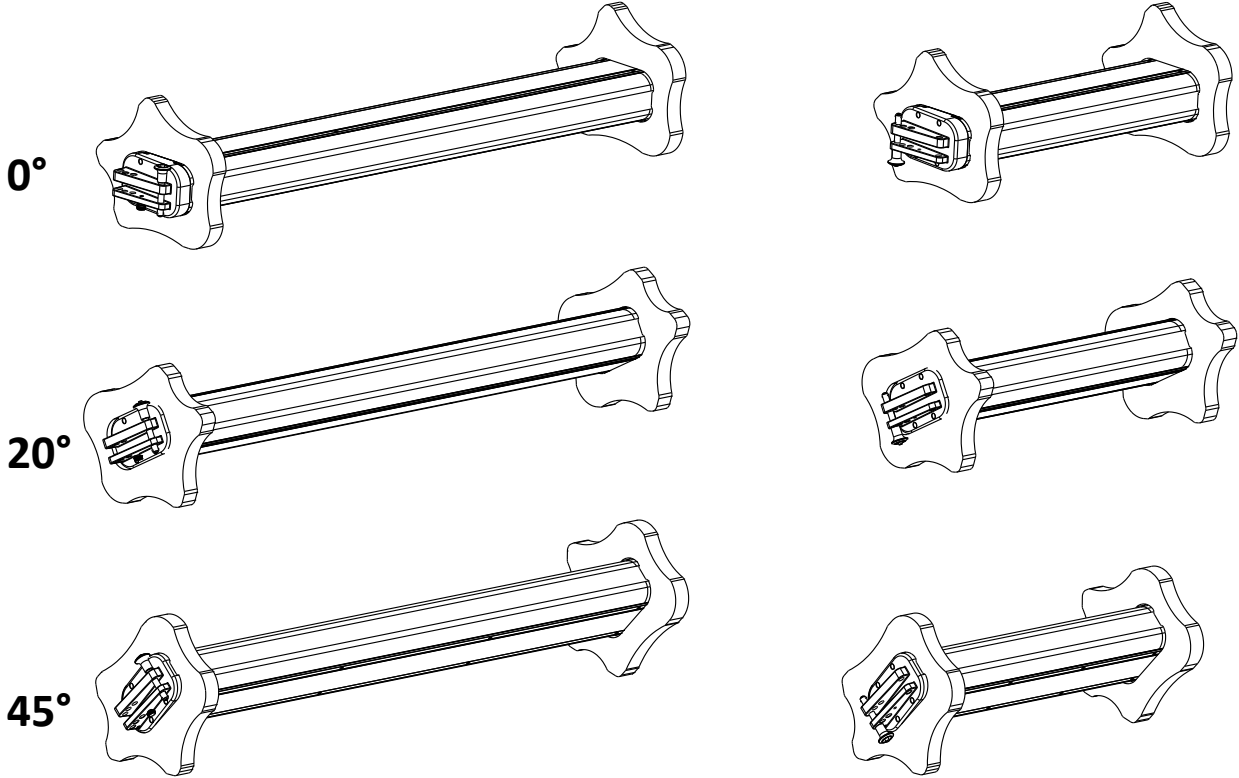

FLOOR/FRONT FILL, SIDE WALL, CEILING/UNDER BALCONY INSTALLATION USING KPTWAX8CL C-BRACKET



WARNINGS:

- KPTWAX8CL can be used in front-fill or monitor applications on stage and in under-balcony or side wall installations in theatres or conference rooms.
- Brackets MUST be installed by qualified personnel in accordance with safe installation practices.
- The ground where the KPTWAX8CL C-bracket is placed needs to be stable and compact.
- When using this support for front fill applications, place it on a stable surface. If it is placed on a front line subwoofer, it must be secured to it using a strap, because the subwoofer vibrations could cause it to fall to ground.

on floor/front fill/stage monitor

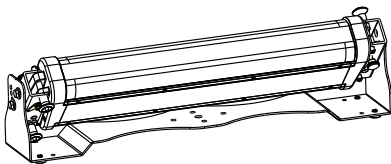

0° +45° (12.5° 4 step)



on side wall (horizontally)

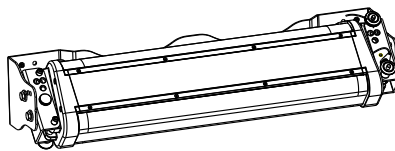

45°-90° (12.5° 4 step)

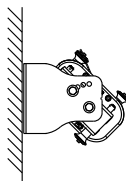

on ceiling/under balcony

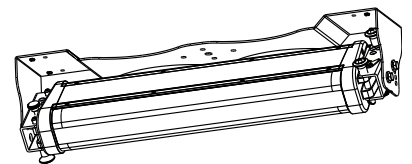

0° -45° (12.5° 4 step)

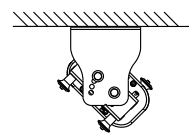



WALL INSTALLATION USING KPTWAX16CLL BRACKETS



WARNINGS:

- No hardware is supplied to install the KPTWAX16CLL to the walls: the hardware to be used depends on the wall structure. Use always the best hardware available, taking in consideration the whole weight of loudspeakers and accessories.
- Brackets **MUST** be installed by qualified personnel in accordance with safe installation practices.
- A single AX16CL or 2x AX8CL speakers can be installed using the KPTWAX16CLL as top and bottom wall brackets.

Column orientation is possible only aiming it at 0°.

*to use these angle setup top and bottom brackets must have same orientation.

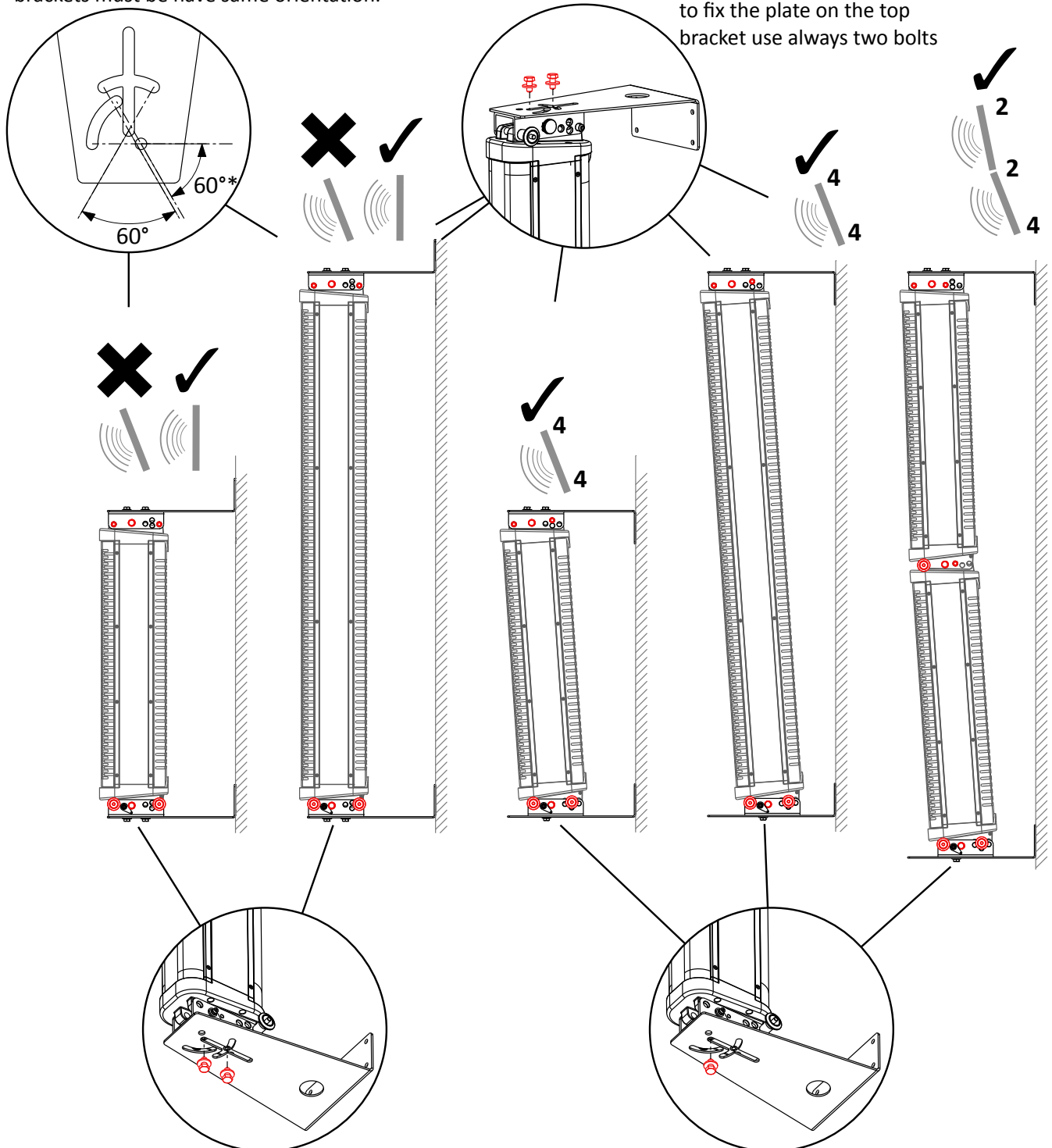



WALL INSTALLATION USING KPTWAX16CL AND KPTWAX16CLL BRACKETS



WARNINGS:

- No hardware is supplied to install the KPTWAX16CL and KPTWAX16CLL to the walls: the hardware to be used depends on the wall structure. Use always the best hardware available taking in consideration the whole weight of loudspeakers and accessories.
- Brackets **MUST** be installed by qualified personnel in accordance with safe installation practices.
- A maximum of 2 x AX16CL or 1 x AX16CL + 2 AX8CL speakers can be installed using the KPTWAX16CL as top and the KPTWAX16CLL as bottom wall brackets.

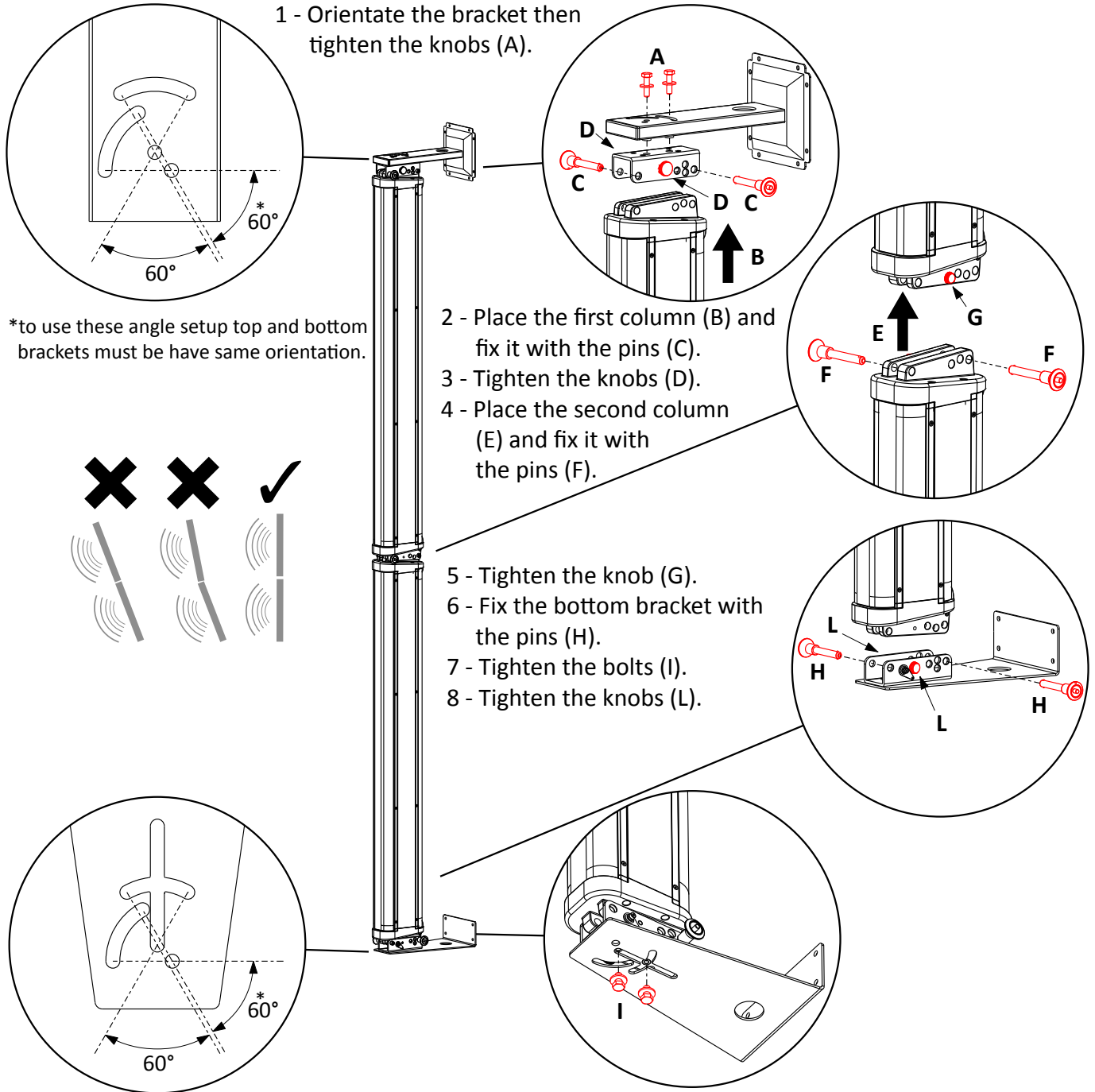



WALL INSTALLATION USING KPTWAX16CL BRACKETS



WARNINGS:

- No hardware is supplied to install the KPTWAX16CL to the walls: the hardware to be used depends on the wall structure. Use always the best hardware available taking in consideration the whole weight of loudspeakers and accessories.
- Brackets **MUST** be installed by qualified personnel in accordance with safe installation practices.
- A maximum of 4 x AX16CL speakers can be installed using the KPTWAX16CL as top and bottom wall brackets.

1 - Orientate the bracket then tighten the knobs (A).

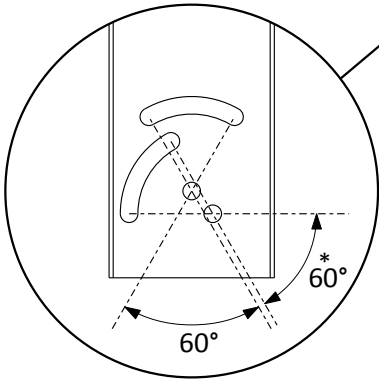

*to use these angle setup top and bottom brackets must have same orientation.

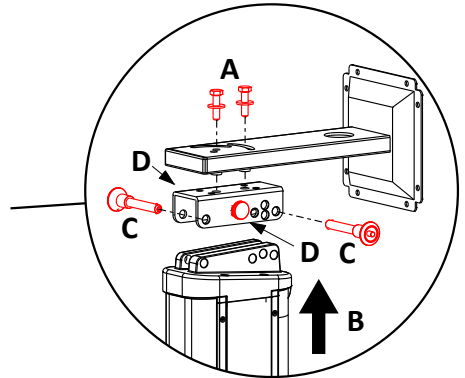
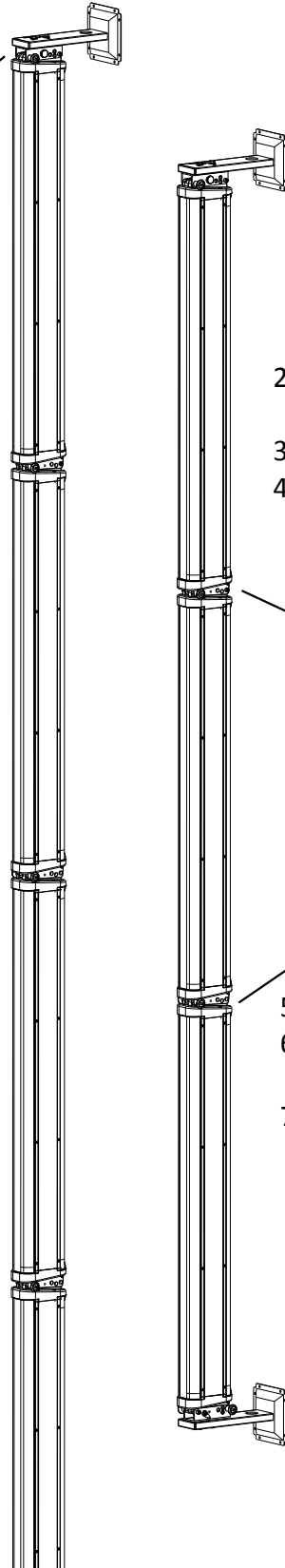
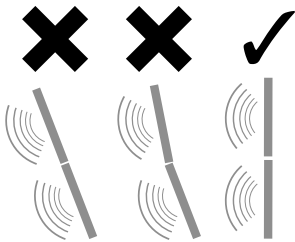

2 - Place the first column (B) and fix it with the pins (C).

3 - Tighten the knobs (D).

4 - Place the second column (E) and fix it with the pins (F).

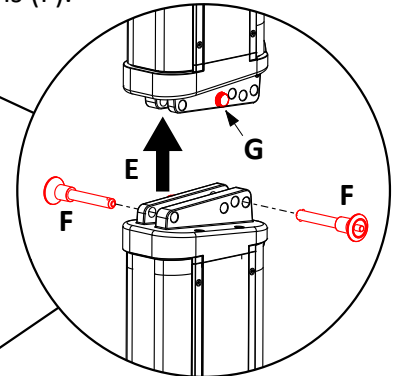

5 - Tighten the knob (G).

6 - Place 3rd and 4th columns in same way.

7 - Fix the bottom bracket as the top.



SUSPENDED INSTALLATION USING KPTAX16CL FLYBAR

Using the **KPTAX16CL** fly bar it is possible to assemble a suspended and unobtrusive vertical array system with a variable size up to 6 elements of AX16CL, or a combination of AX16CL and AX8CL, without exceeding the *120Kg maximum load capacity*. The loudspeakers are linked together in a column using the brackets integrated at each end of the enclosure. Each system can be set properly both acoustically and mechanically using the aiming software.

Each loudspeaker box is fixed to the next one using the two locking pins. The locking pin in the front does not require any adjustment, while the locking pin in the back is used to adjust the splay angle between two adjacent loudspeakers in the array column at 0° or 2°.

Follow the sequence in the figure for fixing the flybar to the first box. Usually this is the first step before lifting up the system. Be careful to insert properly the shackle (1)(2) and the locking pins (3)(4) in the right holes specified by the aiming software.

When lifting the system always proceed gradually step by step, paying attention to secure the flybar to the box (and the box to the other boxes) before pulling up the system: this makes easier to insert properly the locking pins.

Also when the system is released down, unlock gradually the pins.

The centre of gravity of an AX16CL/AX8CL array depends on the number of units and on the splay angle between the units, when the units are arranged to make an arc for the best coverage of the audience. Use always the aiming software to define the correct suspension pinpoint where to fix the straight shackle and the optimal splay angle between units.

Note that the ideal aiming angle often doesn't correspond to the pinpoint: there is often a little difference between ideal aiming and real aiming and its value is the Delta angle: positive delta angle can be adjusted a little using two ropes, negative delta angle are self adjusted a little because the cables weights on the back of the array. With some experience it's possible to consider preventively these required little adjustments.

During the flown set up you can connect the elements of the array to their cables. We suggest to discharge the weight of the cables from the flying pinpoint by tying them with a textile fibre rope, for this reason a ring is present at the end of the flybar that can be used to fix the cable instead of letting them hang freely: in this way the position of the array will be much more similar to the simulation produced by the software.

WIND LOADS

When planning an open-air event it is essential to obtain current weather and wind information. When loudspeaker arrays are flown in an open-air environment, possible wind effects must be taken into account. Wind load produces additional dynamic forces acting on the rigging components and the suspension, which may lead to a dangerous situation. If according to the forecast wind forces higher than 5 bft (29-38 Km/h) are possible, the following actions have to be taken:

- The actual on-site wind speed has to be monitored permanently. Be aware that wind speed typically increases with height above ground.
- Suspension and securing points of the array should be designed to support double the static load in order to withstand any additional dynamic forces.



WARNING!

Flying loudspeakers overhead at wind forces higher than 6 bft (39-49 Km/h) is not recommended. If the wind force exceeds 7 bft (50-61 Km/h) there is a risk of mechanical damage to the components which may lead to a dangerous situation for persons in the vicinity of the flown array.

- **Stop the event and make sure that no person remains in the vicinity of the array.**
- **Lower and secure the array.**



WARNING!

AX16CL and AX8CL must be suspended only using the flying bar KPTAX16CL, with a maximum of 120Kg per flying bar.

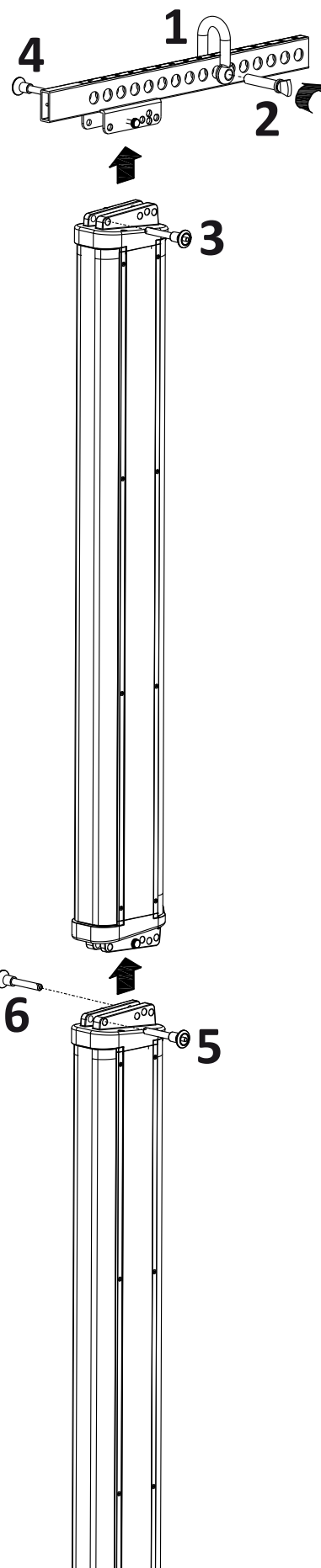



The following examples show some possible configurations with maximum splay angles: the first use 4 x AX16CL, the second a mixed configuration made with 2 x AX16CL and 4 x AX8CL, the third is made using 8 x AX8CL.

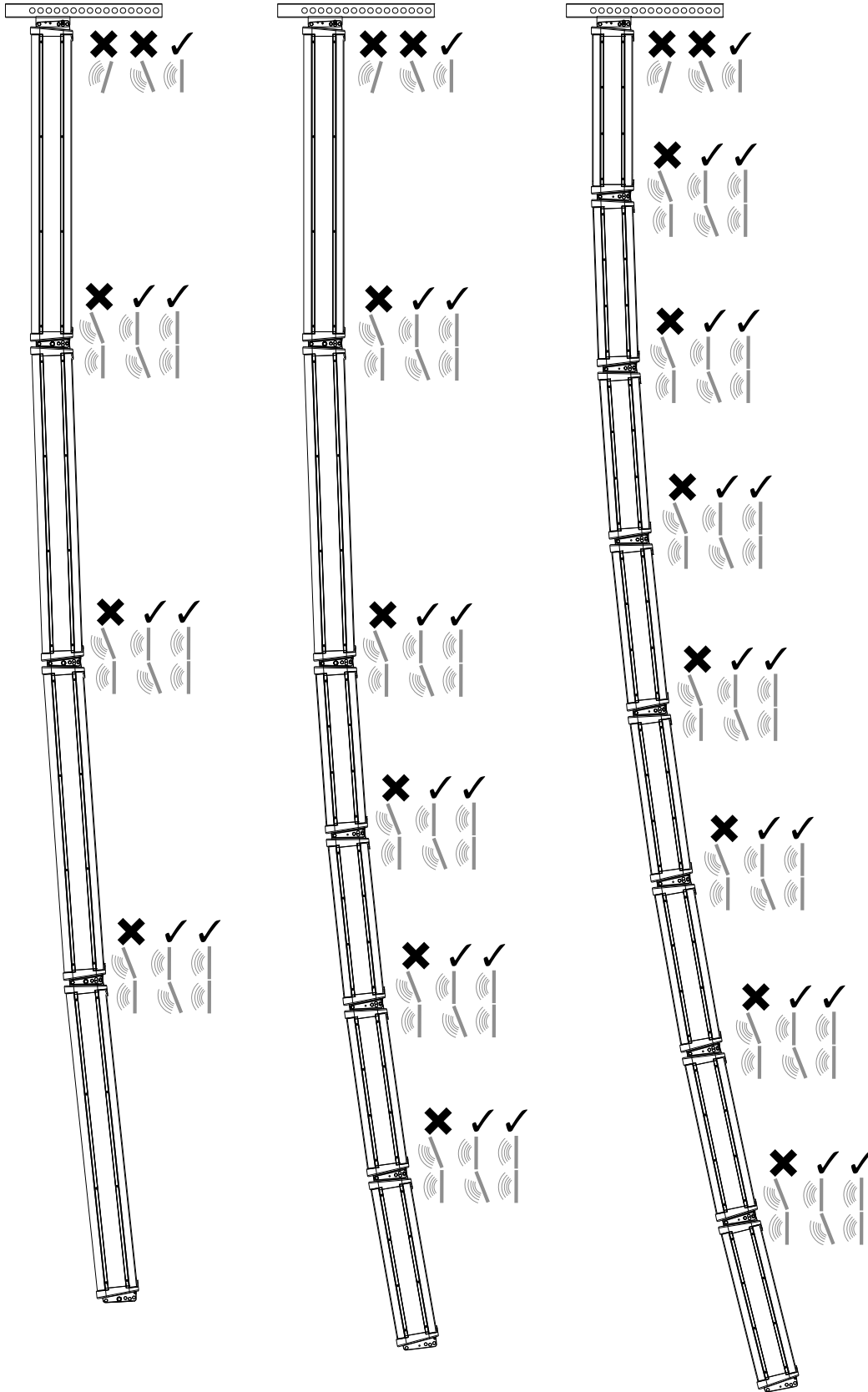



SW212A + AX16CL CONNECTION EXAMPLES

The following examples show all the possible connections between the SW212A amplified subwoofer and the AX16CL column speaker, using the PRESETs available in the subwoofer's DSP. Note that one AX16CL unit corresponds to two AX8CL units.

SW212A + 1 x AX16CL

set preset 1 x AX16CL

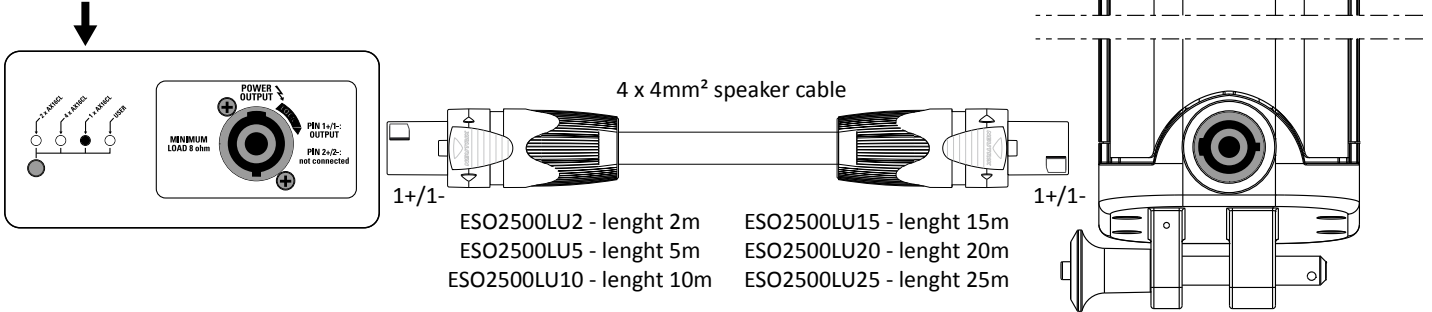

SW212A + 2 x AX16CL

set preset 2 x AX16CL

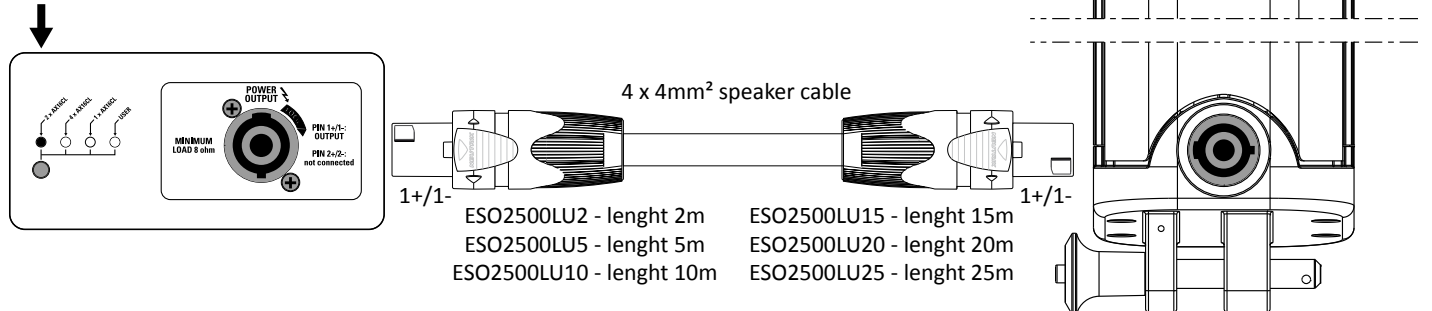



SW212A + 4 x AX16CL

ESO2500LU05 - lenght 0,25m

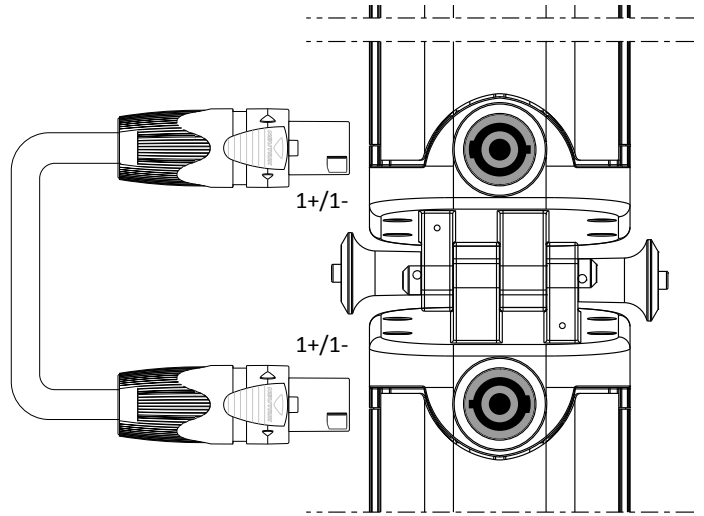

ESO2500LU05 - lenght 0,25m

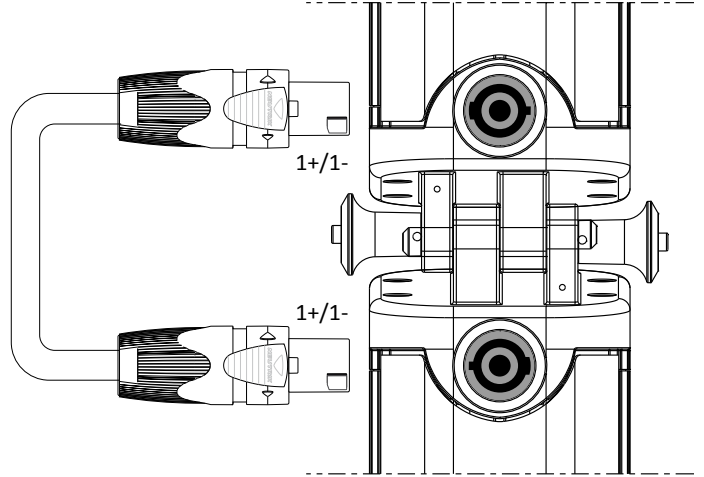

ESO2500LU05 - lenght 0,25m

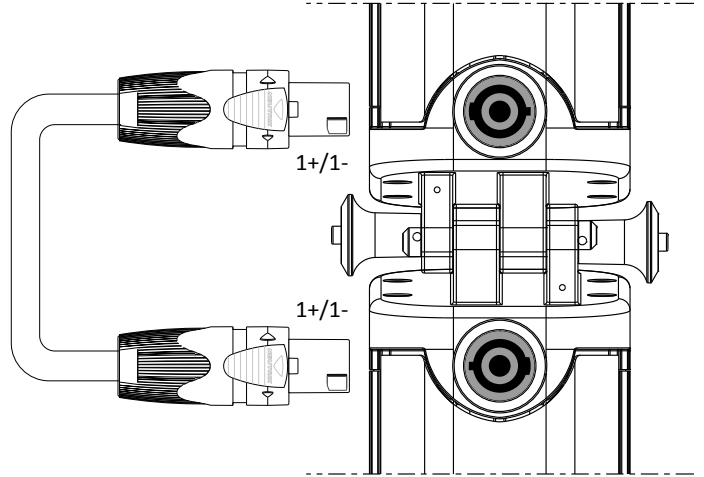

set preset 4 x AX16CL

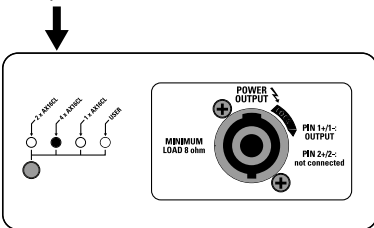

4 x 4mm² speaker cable

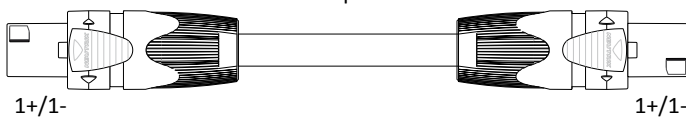

- ESO2500LU2 - lenght 2m
- ESO2500LU5 - lenght 5m
- ESO2500LU10 - lenght 10m
- ESO2500LU15 - lenght 15m
- ESO2500LU20 - lenght 20m
- ESO2500LU25 - lenght 25m

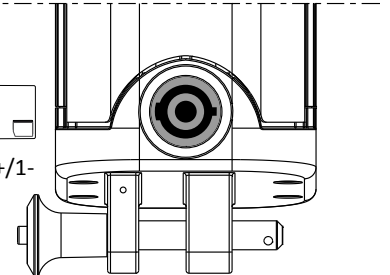



PROEL S.p.A. (World Headquarters) - Via alla Ruenia 37/43 - 64027 Sant'Omero (Te) - ITALY
Tel: +39 0861 81241 Fax: +39 0861 887862 www.axiomproaudio.com

